



Installation & Maintenance Instruction **Freewheel Cage Assembly - NDC**

DOC NO: N-DD-IM-FA266

Issue Date: 22-04-'21

1.) General Instruction:-

- Please give full attention to Safety Notes before installation.
- These instructions regarding installation will only valid, if the products meets the selection criteria before installation.
- Ignore & misconception of installation & operation instruction invalidate the product liabilities or warranty by the NMTG Mechtrans Private Limited; same applies if the product id taken apart or changed.

2.) About NDC:

- NDC cage Assembly consist Inner cage, Outer cage & spring.
- In one direction of rotation there is no contact between the inner and outer ring, the freewheel is in freewheeling operation.
- In the other direction of rotation there is contact between the inner and outer ring; in this direction it is possible to transmit high torque.
- Main function of NDC:
 1. Backstop/Holdback
 2. Indexing/Feeding
 3. Overrunning

Function of NDC:

1. As a Backstop/Holdback:

Backstop function prevent reverse rotation when input drive is discontinue or power supply failure to input drive. Backstop clutch use to prevent damage caused by power supply failure.
2. As a Indexing:

Indexing function allows the conversion of reciprocating motion applied to the driving race of the clutch into unidirectional intermittent motion of the driven race.
3. As a Overrunning:

When drive member rotates faster than driving member, clutch gets disengage automatically. The highest overrunning speed is possible if outer race overruns. This ensures the best performance, reduce heat generation & wear which lead to increase life.

3.) Safety Criteria:

- Installation should be carried out by skilled person only.
- Replacement of any part should be carried out by NMTG only.
- If there is any problem detected in clutch or machine into which it is installed, stopped machine immediately.
- Make sure turning forces are not applied to Freewheel or turning shaft of the equipment when conducting inspection or maintenance.
- Pay special attention to the back stopping application to prevent accidents.
- Frequent starting and stopping will apply excessive force on the mounting. Verify mounting strength.
- Inaccurate installation and mounting, various load conditions, wear and tear of parts, and life Expectancy can all affect the performance of a Holdback. Inspect and maintain periodically and Install a safety devise on your equipment.
- Confirm rotational direction prior to installing.

4.) Design:

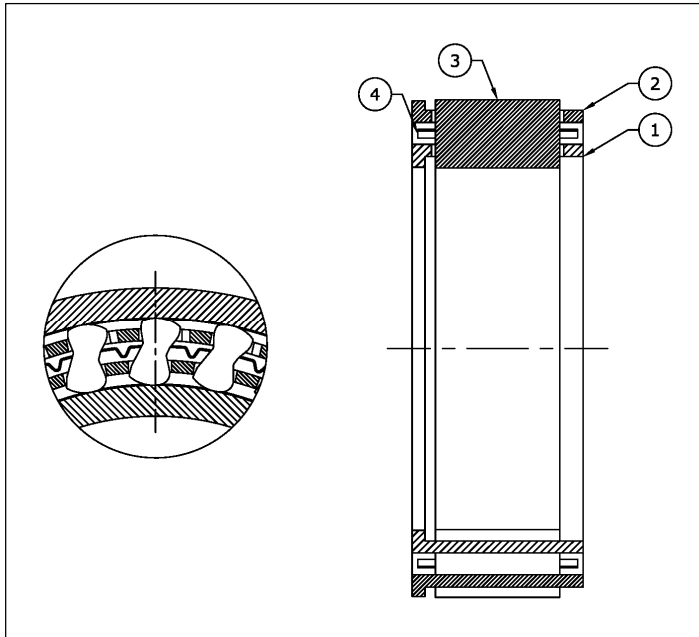

No.	Nomenclature
1	Inner Cage
2	Outer Cage
3	Sprag
4	Spring

5.) Installation:

- If NDC is used with NMTG Supplied races then Tolerance of Shaft for Inner race & Housing for Outer Race will be h6 (or h7) & H7 respectively. If Races are in Customer scope then Case Hardening Steel material with Core Hardness 60±3 for min.0.6 mm depth must be used.
- Core hardness to be 35 to 45 HRC, Surface roughness not to exceed 0.8 µm, Maximum taper between races - 0.007 mm for 25 mm width.
- Maximum permissible Run-out between Inner race & Outer race must be 0.15 mm.
- Determine desired direction of free rotation of shaft.
- For Installation, First push NDC cage assembly between races by hand & Fit Inner race onto the shaft & Outer race into the housing. The inner race or outer race should be slightly rotated in freewheeling direction.
- Rotate Shaft by hand for checking correct Installation of Cage assembly & If reversal of freewheeling direction is required, turn the sprag cage assembly through 180°.
- External Bearing support must be provided for Axial & Radial load.
- Careful handling of cage assembly is essential during installation to prevent sprags being knock out from cage.
- When pushing the NDC Sprag Cage Assembly into the housing, it is important not to hammer the assembly at any time. Hammering by any means will permanently damage the sprags and render them nonfunctional to withstand torque. There is safety by design that even if a single sprag is wrongly oriented, then sprag cage cannot be mounted on shaft.
- Secure position of Outer race & outer cage of the sprag assembly in axial direction with the help of Circlip or retainer ring.
- Proper installation required to avoid torsional vibration.
- **Do not use Grease for Indexing Application. (Use Oil only)**

6.) General Important Notes:

- If a sprag fallout from the cage and is installed wrongly, then sprags will lead to difficulty in fitting the cage assembly, malfunction, and possible destruction of the freewheel assembly.
- If Sprag cage assembly is hard to install on Shaft then check the shaft hub tolerance and make sure it is not out of limit. For ease of assembly we recommend that the inner and outer races be **chamfered at an angle of 15 degrees**. And *shaft hub tolerance should be maintained as recommended by the NMTG's Catalogue*.
- If housing not enclosed, then As Protection against environment condition, there must be sealing-cover arrangement. Please be ensure that no dust, rust, etc. particles come inside freewheel assembly will be damaged.
- During Installation, Do not use excessive force; the spring is easily broken.
- *When clutch is used as backstop, the drive must not be started in the direction opposite the free running direction; otherwise whole assembly may be damaged.*

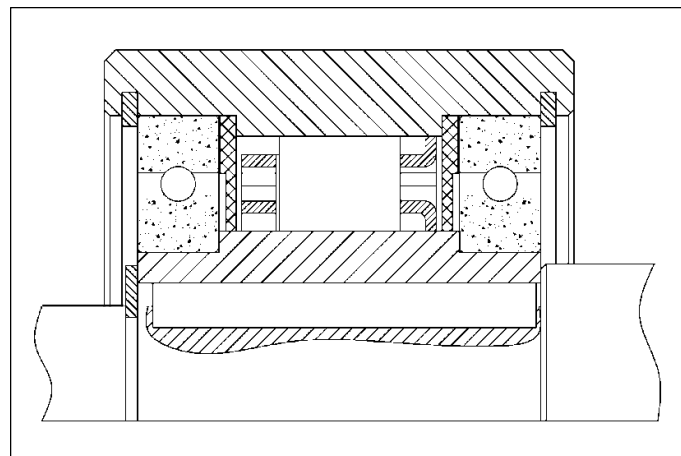
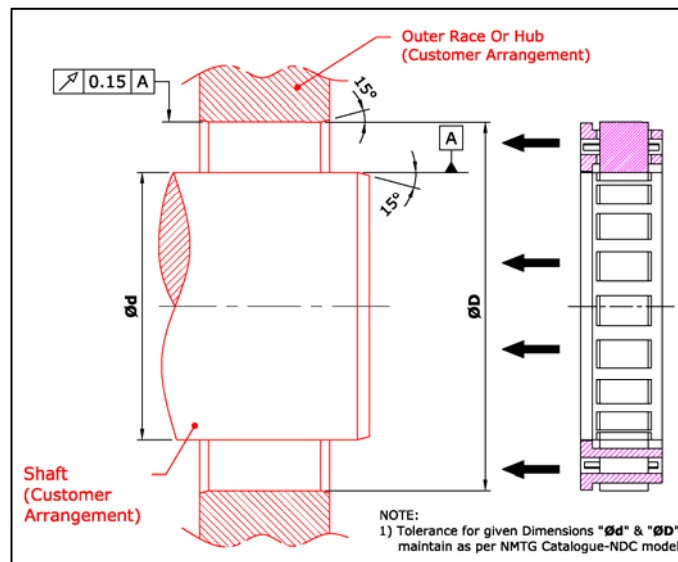

7.) Lubrication:

Oil	Operating -20°c to +20° c Ambient -40° to -15°c	Operating +10°c to +50° c Ambient -15° to +15°c	Operating +40°c to +70° c Ambient +15° to +30°c	Operating +50°c to +85° c Ambient +30° to +50°c
ISO – VG 51519	10	22	46	100
KLUBER	CRUCOLAN 10	CRUCOLAN 22	CRUCOLAN 46	CRUCOLAN 100
MOBIL	VELOCITE No.6	VELOCITE No.10	VACTRA MEDIUM VG46	VACTRA HEAVY VG100
BP	ENERGOL CS10	ENERGOL CS22	ENERGOLCS 46	ENERGOL RC 100
ARAL	SUMOROL CM10	SUMOROL CM22	MOTANOL HE46	DEGOL CL 100T
ESSO	SPINESSO 10 NUTO H10	SPINESSO 22 NUTO H22	TERESSTIC T46 NUTO H46	NUTO 100
FUCHS	RENOLIN MR3	RENOLIN DTA22	RENOLIN DTA46	RENOLIN MR30
SHELL	MORLINA 10	MORLINA 22	MORLINA 46	MORLINA 100
TOTAL	AZZOLA ZS10	AZZOLA ZS22	AZZOLA ZS46	AZZOLA ZS100
DEA	ASTRON HL10	ASTRON HL22	ASTRON HL46	ASTRON HL100

- For long, effective and smooth performance, it is mandatory to check lubricant condition and lubrication level.
- **Note: Don't use oil containing molybdenum sulphide or high-pressure additives or grease of any kind.**
- Initially change oil after 10 hours of operation. Afterwards change lubricant every 2000 hours and every 1000 hours in a dirty environment. Oil level and oil condition as well as rotating seals should be checked regularly. For working temperature below -40°C and above 100°C, Please contact us.
- When working temperature is above 80°C, then check lubrication regularly.
- For indexing application, oil with kinematic viscosity 10 mm²/s at normal working condition.

Grease:

Temp. Range	-50°c to +140°c
Manufacturer	Grease
OKS	OKS 475
KLUBER	ISOFLEX LDS 18 SPECIAL A
MOLYKOTE	MOLYKOTE G-1023
BP	ASV RBL 33

- Generally grease is used for long maintenance free. Ready for both horizontal and vertical mounting application. We suggest to clean, remove, inspect and re-grease after two years of operation.
- Excessive amount of grease may lead to malfunction of clutch. Fill grease approx. 30% to 40% of free space.

Note: Do not use Grease for Indexing Application. (Use Oil only)

8.) Oil Level:.....(If Inner Race & Outer Supplied by NMTG)

- Oil lubrication is provided with particular oil mention in above table.
- Check oil level every month or 160 Hr. of operation, which take place first. For indexing application where operating speed is above 160 strokes per minute require frequent oil level inspection.
 - **For overrunning and backstopping:**
- First rotate clutch as shown in fig. 01.
- Remove oil screw 2 & 1 or 3 & 1 and add oil through lubrication hole 1 until oil starts flow from hole 2 or 3.(Fill ½ of free space)
- Tight lubrication screw 2 & 1 or 3 & 1 with washer to prevent leakage.
- **For indexing:**
- First rotate clutch as shown in fig. 02.
- Remove lubrication screw 2 & 1 and add oil from hole 2 until oil starts flow from hole 1. (Fill 7/8 of free space)
- Tight lubrication screw 2 & 1 with washer to prevent leakage.

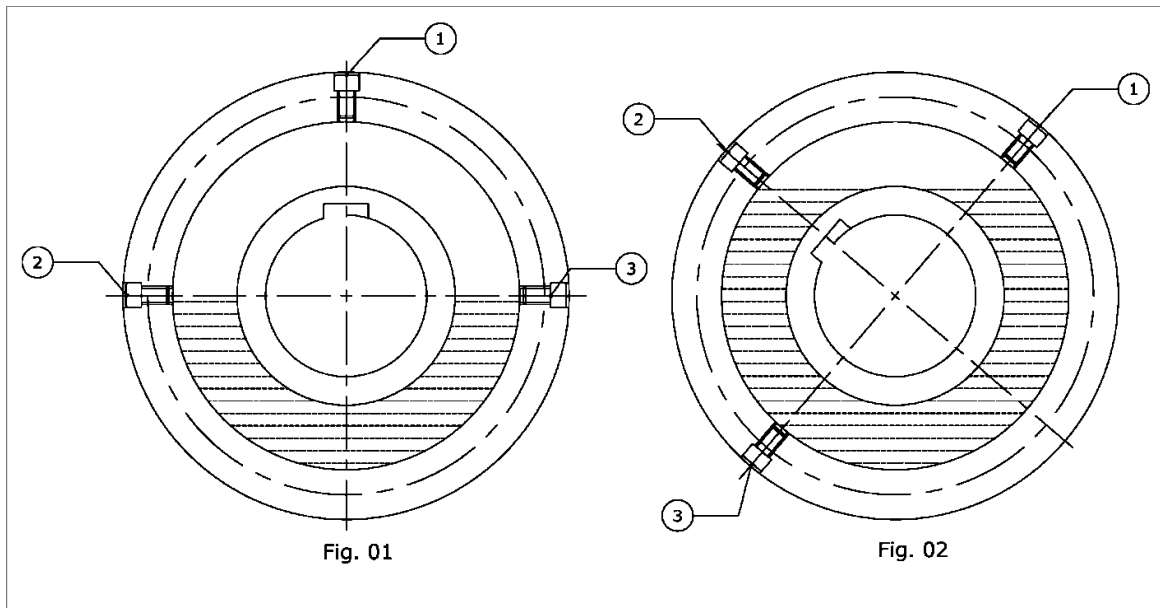

Oil/Grease change:(If Inner Race & Outer Supplied by NMTG)

- Rotate clutch till the lubrication screw reached at bottom position.
- Remove lubrication screw to drain oil from clutch. After oil drainage, fill whole clutch with mineral spirits and tight lubrication screw.
- Rotate clutch for some time to break up and dissolve any oily residue.
- Remove mineral spirits by removing lubrication screw and tight screw.
- Lubricate clutch with specified oil/grease.
- When replacing of oil take place, drain whole oil and clean clutch with mineral spirits. Do not mix oil with any solvent containing carbon sulphide.
- Wipe all grease form clutch.
- Fill new grease into all fittings until clean grease flows out around the oil seal of the clutch.
- Fill lubrication at normal working temperature condition.

9.) Disposal:

- Freewheel one way clutch is metallic material coated with Oil or Grease. So, Metallic materials are recyclable but Lubricants must be disposed separately.

10.) Preservation & Storage Instruction:

- NMTG Product is supplied with Rust & Corrosion Protection as per below instruction for short term storage.
- This protection is renewed at regular intervals which depends on Environmental condition at Storage site. (Temperature, Atmosphere, etc.)
- **Maximum Storage period is 6 Months for Short-term Storage.**

Please follow Instruction for Preservation & Storage of NMTG Products:

- Once NMTG Product is used then clean all its parts with clean cloth.
- Lubricate all parts with rust preventive oil S-VCI 415 or equivalent & assemble as it was & packed in plastic bag.
- After wrapping in plastic bag, Material is packed by S-VCI 131/113 or equivalent rust preventive paper & store.
- Keep it in dry place and free from dust.
- Do not expose to open or corrosive environment.
- Keep away from direct Sunlight.
- Avoid Mechanical Shock & Vibration.
- Storage Temperature: -10 to +60°C.
- Relative Humidity: Maximum 95%, non-condensing.

For Long term Storage (1 Year):

Please follow Instruction for Preservation & Storage of NMTG Products:

- Once NMTG Product is used then clean all its parts with clean cloth.
- Lubricate all parts with rust preventive oil S-VCI 415 or equivalent & assemble as it was & packed in plastic bag.
- After wrapping in plastic bag, Material is packed by S-VCI 131/113 or equivalent rust preventive paper & store in corrugated box.
- After wrapping corrugated box in Vacuum bag, Material is packed in wooden box.
- Keep it in dry place and free from dust.
- Do not expose to open or corrosive environment.
- Keep away from direct Sunlight.
- Avoid Mechanical Shock & Vibration.
- Storage Temperature: -10 to +60°C.
- Relative Humidity: Maximum 95%, non-condensing.

