

HOLDBACK - NRHD

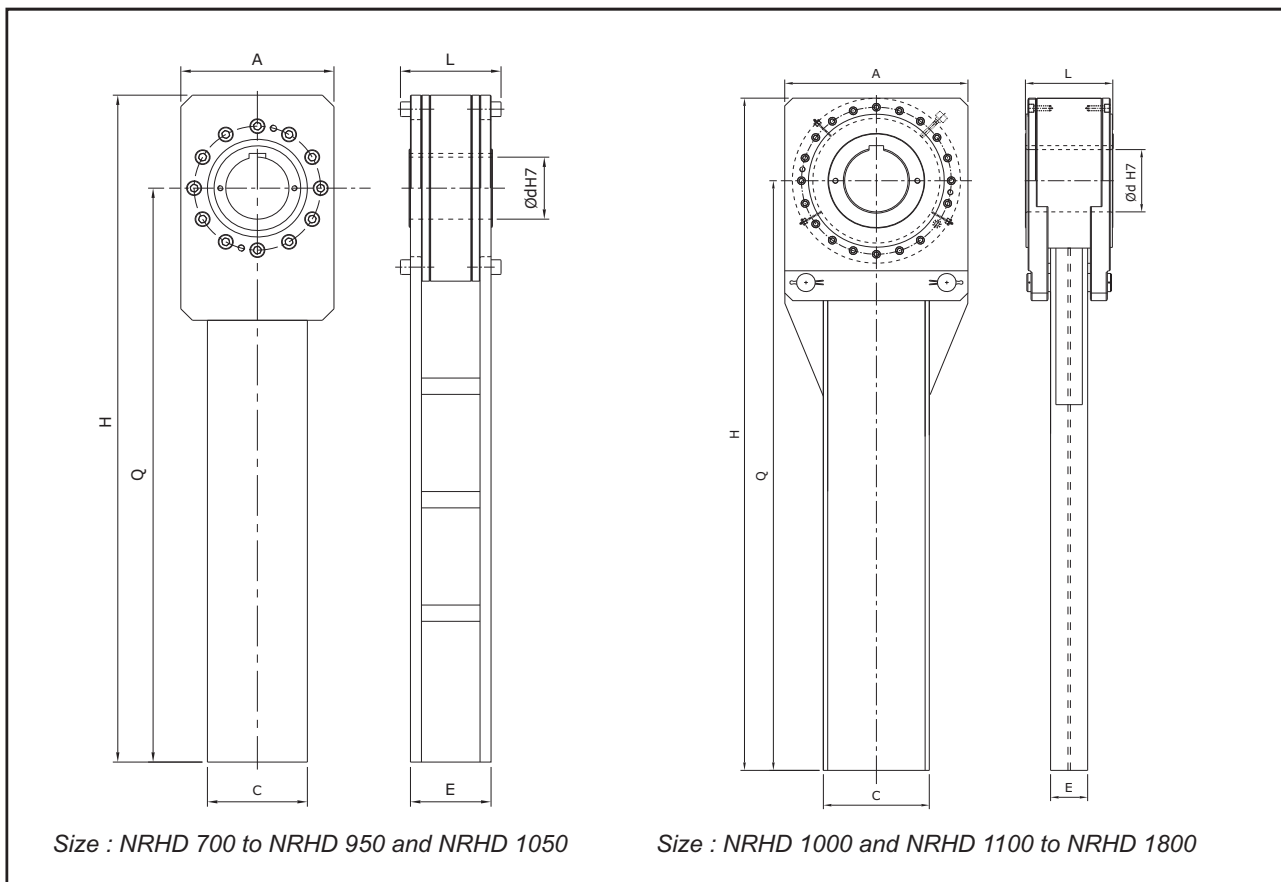

- Contains bearing support and sprags with Lever arm arrangement.
- Oil / Grease, Ready for installation.
- Function : Backstopping.
- Applications : For low speed application, Conveyor belt systems and Bucket Elevators.

Code No	Nominal Torque (Nm)	Max. Overrunning speed Inner race (r/min)	Dimensions							Weight kg
			Bore dH7 Max.	A	C	E	H	L	Q	
NRHD 700	5062	620	87	203	152	146	914	171	813	68
NRHD 775	10125	540	95	248	203	185	1089	229	965	155
NRHD 800	16200	460	114	267	254	197	1099	241	965	180
NRHD 900	24975	400	138	305	254	188	1372	238	1219	240
NRHD 950	31050	360	178	356	305	197	1753	254	1575	265
NRHD 1000	37800	360	178	432	200	100	2042	222	1829	249
NRHD 1050	60750	360	178	356	305	261	2007	318	1829	300
NRHD 1100	60750	360	178	432	200	100	2042	254	1829	360
NRHD 1200	124875	250	229	584	250	125	2261	279	1981	589
NRHD 1300	148500	220	254	635	300	140	2413	305	2105	758
NRHD 1400	189000	200	305	762	450	150	2718	330	2388	997
NRHD 1450	256500	200	305	762	450	150	2718	381	2388	1133
NRHD 1500	391500	200	305	787	450	150	2718	448	2388	1105
NRHD 1600	503550	140	356	826	500	180	3150	489	2743	1540

Notes :-

- $T_{max} = 2 \times T_{nom}$.
- Key way dimensions upon request by customers.
- All Dimensions are in mm. Other sizes are on request.
- Dimensions / Design subject to Modification without any prior intimation.